

## Circa 1880 Mounting Module 23" Rack Mount

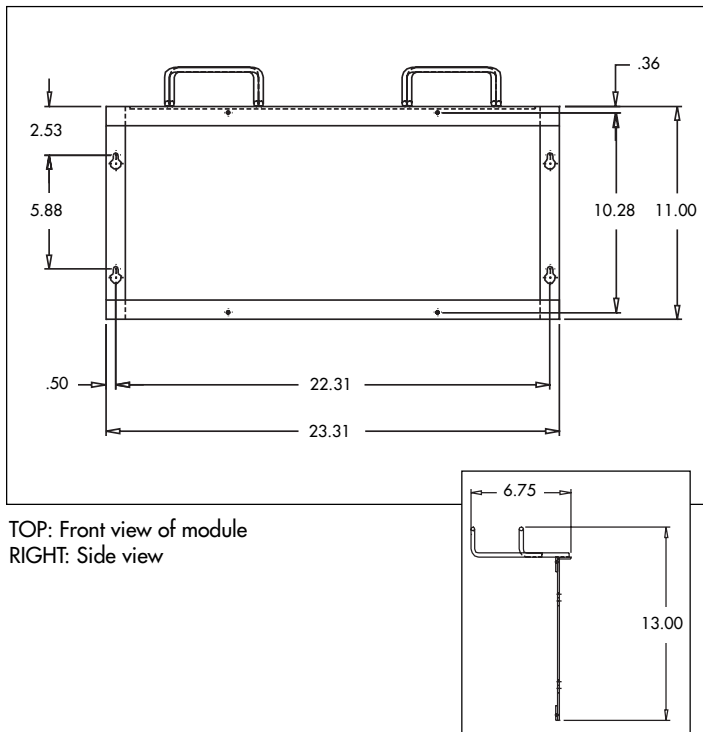

TOP: Front view of module  
RIGHT: Side view

Homaco Circa 1880 Mounting Modules accommodate Circa 1880ENA1/NSC-100 protectors\* and rack-mount to Homaco 23" equipment racks. Each bracket provides built-in cable management to easily route and clearly trace jumpers, simplifying cable installation and maintenance.

### Features

- Mounts (1) 100-pair Circa 1880ENA1/NSC-100 protector per module
- Use for 110 block applications
- High-density installations are managed within a small space
- Keyhole module mounting for quick installation
- Six mounting modules can be installed on each side of a Homaco 23" rack
- Welded steel construction
- Durable black finish
- Ships fully assembled to reduce installation time
- Mounting hardware included
- Meets EIA-310 standards

### Ordering Information:

Catalog No.	Block Capacity*	No. of Pairs	Dimensions	Ship Weight
110D-1880P-XLB	1	100	13.00"H x 23.31"W x 6.75"D	8 lbs

\*Protectors not included.

**1875 W. Fullerton Ave. ■ Chicago, IL 60614**

**Phone: 888-446-6226 ■ Fax: 773-384-6080 ■ www.homaco.com**

M01-0020-0102