

# Porta Mounting Module

## 23" Rack Mount

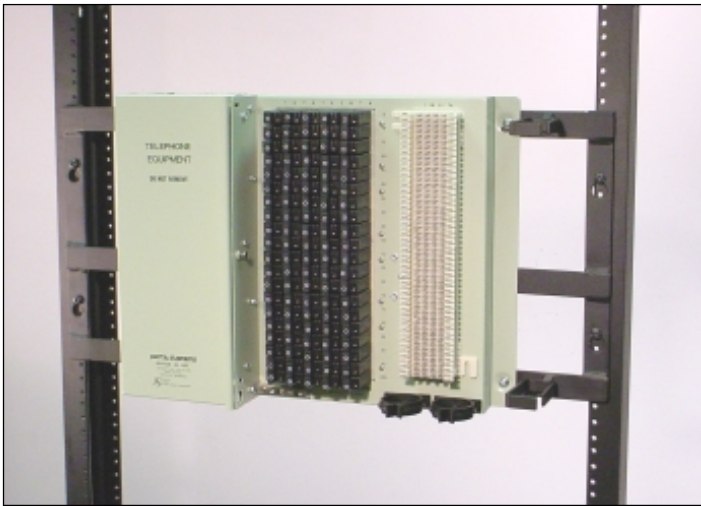

Homaco Porta Mounting Modules accommodate 50-pair or 100-pair Porta Series 24 Building Entrance Protector Packs™ and rack-mount to Homaco 23" equipment racks. Each module provides built-in cable management to easily route and clearly trace jumpers, simplifying cable installation and maintenance.

### Features

- Mounts (1) 50-pair or 100-pair Porta Series 24 Building Entrance Protector Pack
- Use for 66 block and 110 block applications
- High-density installations are managed within a small space
- Keyhole module mounting for quick installation
- Five mounting brackets can be installed on each side of a Homaco 23" rack
- Welded steel construction
- Durable black finish
- Ships fully assembled to reduce installation time
- Protector pack mounting hardware included; hardware used to mount module to rack included
- Meets EIA-310 standards

### Ordering Information:

Catalog No.	Block Capacity*	Dimensions	Ship Weight
50M-201-24100-R23	1	11.00"H x 23.31"W x 4.25"D	8 lbs

\*Protector packs not included.

LEFT: Front view of module  
RIGHT: Side view

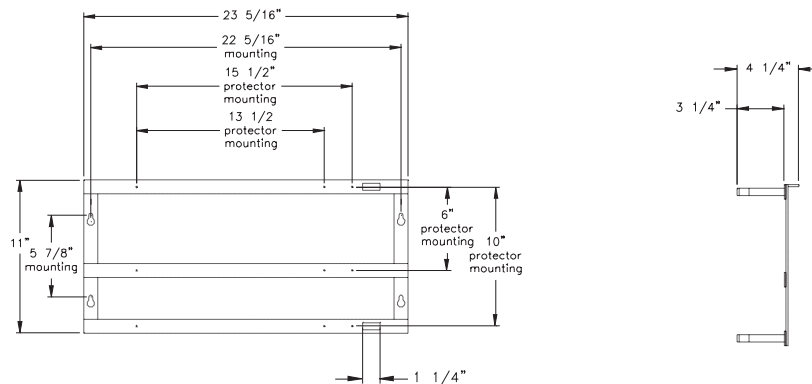

**1875 W. Fullerton Ave. ■ Chicago, IL 60614**

**Phone: 888-446-6226 ■ Fax: 773-384-6080 ■ www.homaco.com**