

110D Stand-Off Wall Bracket

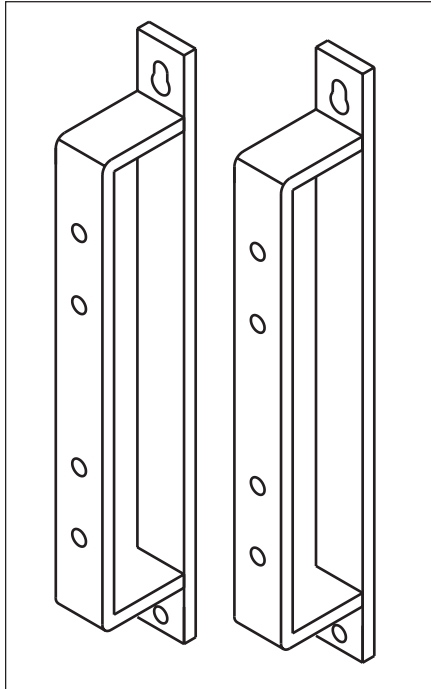

Homaco's 110D Stand-Off Wall Bracket allows you the extra space you need to mount a 110D Homaco Wall Module. The 2" stand off provides you added space for Category 5E and 6 cable. The module easily mounts on the bracket and then to the wall.

Features

- Use for 110 block wall mount module applications
- Keyhole slots allow for quick installation
- Bracket provides a 2-inch standoff
- Includes two brackets
- 12-24 hardware included for attaching module to brackets
- Mounts on any Homaco 110D Wall Module:
 - 110D-600-19
 - 110D-900W
 - 110D-1800W

Specifications:

- Made of steel

Ordering Information:

Catalog No.	Dimensions (HxWxD)	Ship Weight
110D-WBRK	10.84" x 1.00" x 2.00"	2 lbs

Greystone Finish

Catalog No.	# of kits needed
110D-600-19	1
100D-900W	1
110D-1800W	2

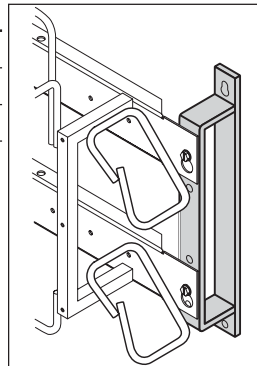

1875 W. Fullerton Ave. ■ Chicago, IL 60614

Phone: 888-446-6226 ■ Fax: 773-384-6080 ■ www.homaco.com