

End Closing Bars

Features:

- Use to junction runway stringers of different widths or to close end of runway*
- Solid bar with dove gray finish
- Constructed of steel

Catalog No.	Description	Kit Contents	Ship Weight
2-E1-CD-5	For 1-1/2" stringers	(1) 5" End Closing Bar	2 lbs
2-E1-CD-10	For 1-1/2" stringers	(1) 10" End Closing Bar	3 lbs
2-E1-CD-12	For 1-1/2" stringers	(1) 12" End Closing Bar	3 lbs
2-E1-CD-18-2	For 2" stringers	(1) 18" End Closing Bar	4 lbs
2-E1-CD-20-2	For 2" stringers	(1) 20" End Closing Bar	4 lbs
2-E1-CD-25-2	For 2" stringers	(1) 25" End Closing Bar	5 lbs
2-E1-CD-30-2	For 2" stringers	(1) 30" End Closing Bar	9 lbs

*Corner Clamps available separately.

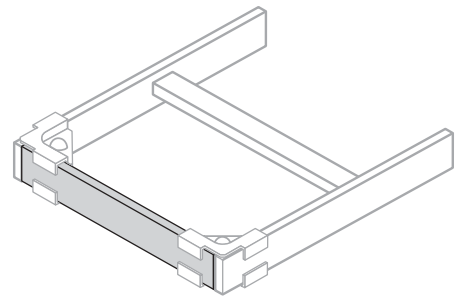

Rubber End Caps

Features:

- Protective rubber covers exposed ends of runway stringers, tubes, and bars
- Constructed of black rubber
- Sold in pairs

Catalog No.	Description	Kit Contents	Ship Weight
2-E1-25C-A	For 1-1/2" stringers	(2) Rubber End Caps	1 lb
2-E1-25C-B	For 2" stringers	(2) Rubber End Caps	1 lb

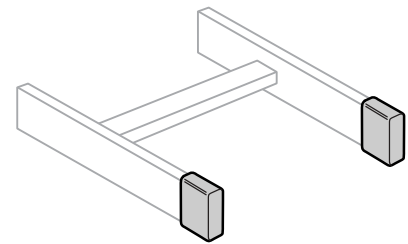

Panel Adapters

Features:

- Mounts 19" equipment and accessories to a 23" equipment rack
- Each set consists of two adapters*
- 12-24 hardware included
- Constructed of steel

Catalog No.	Mounting spaces (1.75")	A	Ship Weight
PA-93-1D	1	1.75"	1 lb
PA-93-2D	2	3.50"	1 lb
PA-93-3D	3	5.25"	1 lb
PA-93-4D	4	7.00"	1 lb
PA-93-5D	5	8.75"	2 lbs

*Dove gray finish. Mounting hardware included.

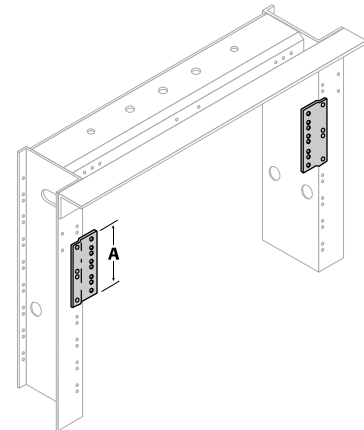

Unequal Flange Junction Kit

Features:

- Joins two Unequal Flange Racks
- Dove gray and yellow zinc dichromate finish
- Constructed of steel

Catalog No.	Description	Kit Contents	Ship Weight
JKIT	Unequal flange rack junction at base	(3) Junction Plate (1) Tube Spacer (1) Spacer Plate (1) 3/8-16" x 5" HHCS (1) 3/8-16" x 7/8" HHCS (4) 3/8" Lockwasher (2) 3/8-16" Hex Nut (12) 12-24 Mounting Screws	1 lb

