

## Cable Management Products

### DirectPath Cable Management System

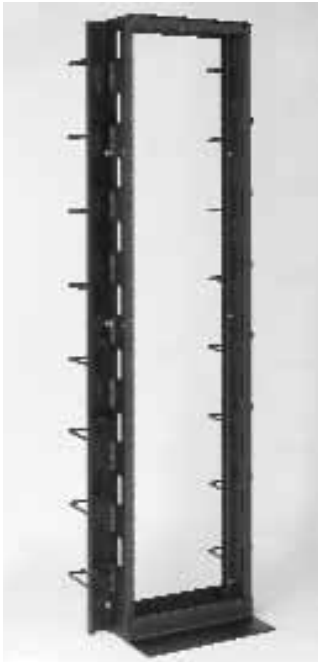

19-84-CSMR6 DirectPath Cable Management Rack, rear view.

Homaco® DirectPath Cable Management Racks are available in 3" or 6" uprights. Uprights offer openings that efficiently route and manage horizontal cables transitioning vertically. EZ-Feed openings along the uprights allow easy cable transitions, assuring appropriate cable bend radius. It is equipped with two DirectPath Vertical Organizers with feed-through holes on each upright. Rings on the front keep patch cords orderly; velcro on the back keep bundles in place, providing you a double sided organizer to manage cables.



*The DirectPath System routes cables easily through the upright into the vertical organizer... providing you with minimum stress on the cables.*

**Features:**

- Shipped fully assembled
- One-Wrap® brand Velcro (included) attaches beneath EZ-Feed openings for additional cable support 3" Vertical Organizers are attached to each upright
- Patented self-support base with self-squaring assembly
- Standard 5/8", 5/8", 1/2" universal mounting hole pattern
- 12-24 mounting hardware included
- Mounting holes are roll formed for work hardened thread system
- Equipped with 1/2" junctioning holes for securing multiple-rack lineups
- Heavy duty 6061-T6 aluminum rack construction for 750 lb. load rating
- Meets UL 1863 Standard for Communication Circuit Accessory
- Meets EIA-310 standards

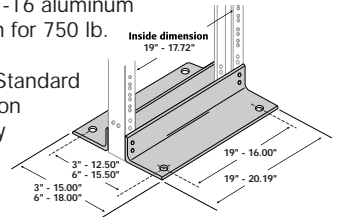

PART NO.	RACK CHANNEL DEPTH	VERTICAL ORGANIZER DEPTH	DIMENSIONS	LOAD RATING	SHIP WEIGHT
19-84-CSMR3	3	3	84.00"H x 26.00"W x 15.00"D	750 lbs	50 lbs
19-84-CSMR6	6	3	84.00"H x 26.00"W x 18.00"D	750 lbs	55 lbs

Black finish.

### DirectPath Vertical Organizers - Double-Sided

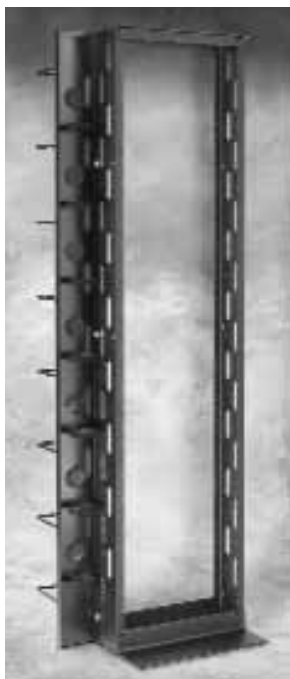

VO-84-CM6E mounted on 19-84-6T2SD-CMB.

Homaco DirectPath Vertical Organizers attach to equipment racks to provide front and back vertical cable run containment. Unobstructed troughs smoothly maintain vertical cable bend radius. Homaco DirectPath Vertical Organizer Covers (available separately) conceal and protect cables within the Vertical Organizers. Covers easily snap on and off organizer rings without the use of tools. All DirectPath Vertical Organizers and DirectPath Vertical Organizer Covers are sold individually.

**Features:**

- Use to provide vertical management between racks or at the end of line-up
- Cables are easy to manage and maintain
- Organizer front cable rings contain patch cords
- Velcro® provides additional cable support and a neat installation
- Organizer feed-through openings allow front-to-rear cable travel
- One-piece design for quick installation
- Includes mounting hardware
- Constructed of top quality 16-gauge steel
- Meets EIA-310 standards

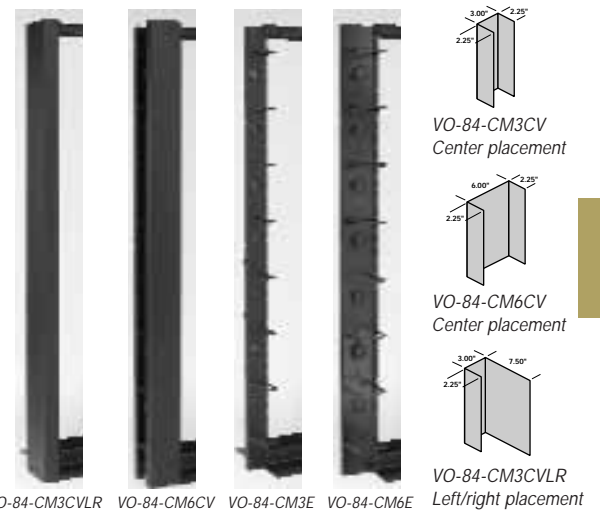

PART NO.	CHANNEL WIDTH	DIMENSIONS	CABLE CAPACITY*	
			FRONT	REAR
<b>DirectPath Organizers</b>				
VO-84-CM3E	3	83.53"H x 3.00"W x 7.50"D	250	288
VO-84-CM6E	6	83.53"H x 6.00"W x 7.50"D	500	576

Black finish. \*Cable diameter of 0.25".

PART NO.	CHANNEL WIDTH	DIMENSIONS	COVER PLACEMENT
<b>DirectPath Organizer Covers</b>			
VO-84-CM3CV	3	83.53"H x 3.00"W x 2.25"D	Center
VO-84-CM3CVLR*	3	83.53"H x 3.00"W x 7.50"D	End
VO-84-CM6CV	6	83.53"H x 6.00"W x 2.25"D	Center

Black finish. \*Use at either the left or right end of rack installation.

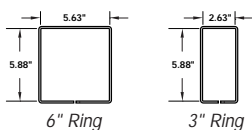

## Cable Management Products

### Vertical Organizers

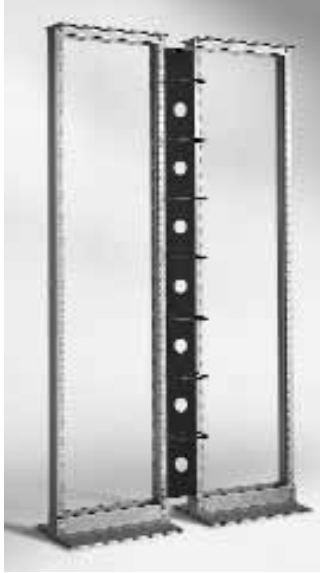

Vertical Organizers (VO-84-T6FTE)

Homaco® patented Vertical Organizers save time and money during moves, adds, and changes to patch panels. Rings in the front organize patch cords with ease. A rear, U-shaped channel is formed either between equipment racks or at the end of a lineup to provide a pathway for delivering horizontal cables to patch panels. The 6" width is used between fully loaded racks; the 3" width is used with a single rack, at the end of a lineup or between partially loaded racks.

**Features:**

- Rings are spaced 9" apart, center ring is spaced 13" apart from others

- Three-inch organizers (2.63"W x 4.13"D) accommodate 250 patch cords
- Six-inch organizers (5.63"W x 4.13"D) accommodate 500 patch cords
- Shipped in two sections for easy on-site assembly
- Sturdy steel construction
- Mounting hardware included:
  - 3 of each for 3", 6 of each for 6"
  - 3/8 hex nuts
  - 3/8 bolts
  - 3/8 lock washers
  - 3/8 flat washers
- Fits all EIA-310 compliant equipment racks

PART NO.	DESCRIPTION	CHANNEL WIDTH	DIMENSIONS	SHIP WEIGHT
VO-84-T3E	Solid	3	79.00"H x 3.00"W x 5.31"D	10 lbs
VO-84-T6E	Solid	6	79.00"H x 6.00"W x 5.31"D	10 lbs
VO-84-T3FTE	Feed-through holes	3	79.00"H x 3.00"W x 5.31"D	10 lbs
VO-84-T6FTE	Feed-through holes	6	79.00"H x 6.00"W x 5.31"D	10 lbs
VO-96-T3E	Solid	3	90.00"H x 3.00"W x 5.31"D	13 lbs
VO-96-T6E	Solid	6	90.00"H x 6.00"W x 5.31"D	13 lbs
VO-96-T3FTE	Feed-through holes	3	90.00"H x 3.00"W x 5.31"D	13 lbs
VO-96-T6FTE	Feed-through holes	6	90.00"H x 6.00"W x 5.31"D	13 lbs

Black finish.

### Vertical Organizers Covers

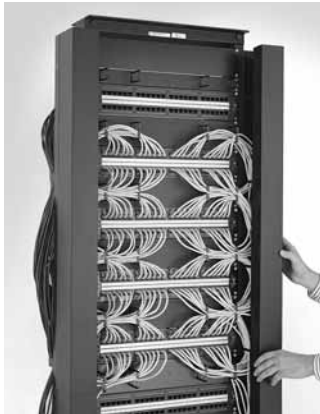

Vertical Organizer Covers (VO-84-T3CVL), left and (VO-84-T3CVR), right.

To conceal patch cords and add a finished look to your installation, use Homaco Vertical Organizer Covers. Made of steel for strength and durability,

they easily attach to the rings of our Vertical Organizers to keep patch cords hidden and protected (no tools needed.)

PART NO.	CHANNEL	DIMENSIONS	SHIP WEIGHT
VO-84-T6CVE	6	79.00"H x 6.00"W x 2.25"D	10 lbs
VO-84-T3CVL*	3	79.00"H x 3.00"W x 5.25"D	11 lbs
VO-84-T3CVR*	3	79.00"H x 3.00"W x 5.25"D	11 lbs
VO-84-T3CME	3	79.00"H x 3.00"W x 2.25"D	10 lbs
VO-96-T6CVE	6	90.00"H x 6.00"W x 2.25"D	12 lbs
VO-96-T3CVL*	3	90.00"H x 3.00"W x 5.25"D	13 lbs
VO-96-T3CVR*	3	90.00"H x 3.00"W x 5.25"D	13 lbs
VO-96-T3CME	3	90.00"H x 3.00"W x 2.25"D	12 lbs

Black finish. \* L = left side, R = right side.

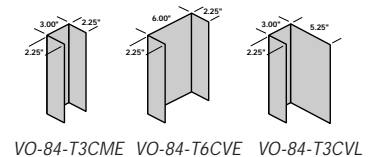

### Vertical Control Brackets

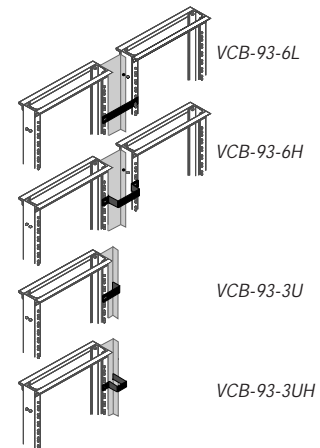

Vertical Control Brackets attach to equipment racks to provide secure backside cable containment; use with any Vertical Organizer for double-sided management. Homaco recommends using four brackets on an 84" rack.

**Features:**

- Use with Vertical Organizers for double-sided management
- Sold individually
- Includes 12-24 mounting hardware
- Constructed of steel

PART NO.	INSIDE DIMENSIONS	DIMENSIONS	CABLE CAPACITY	SHIP WEIGHT
<b>Use with 3" wide Vertical Organizers</b>				
VCB-93-3L	3.00"W x 3.00"D	1.00"H x 5.68"W x 0.06"D	180	0.4 lb
VCB-93-3U	3.00"W x 3.00"D	1.00"H x 3.65"W x 2.73"D	180	0.4 lb
VCB-93-3H	3.00"W x 6.00"D	1.00"H x 5.68"W x 3.00"D	360	0.5 lb
VCB-93-3UH	3.00"W x 6.00"D	1.00"H x 3.65"W x 3.69"D	360	0.4 lb
<b>Use with 6" wide Vertical Organizers</b>				
VCB-93-6L	6.00"W x 3.00"D	1.00"H x 8.56"W x 0.06"D	360	0.5 lb
VCB-93-6U	6.00"W x 3.00"D	1.00"H x 7.28"W x 2.73"D	360	0.3 lb
VCB-93-6H	6.00"W x 6.00"D	1.00"H x 8.56"W x 6.00"D	720	0.3 lb
VCB-93-6UH	6.00"W x 6.00"D	1.00"H x 7.28"W x 3.69"D	720	0.3 lb

Black finish.

## Cable Management Products

### Cable Rings

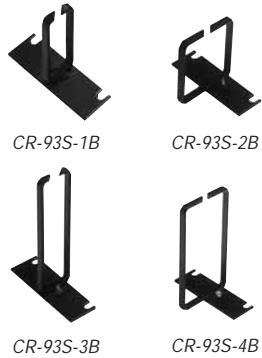

**Features:**

- Mount to any equipment rack, including Swing-EZs, for versatile vertical jumper management
- Channel cables from the floor or ceiling to patch panels
- CR-93S-1B and CR-93S-3B rings fit within the width of a rack; they are designed for smaller, single-rack installations or where the width of the rack cannot be exceeded

- Larger capacity CR-93S-2B and CR-93S-4B rings mount between adjacent racks and equal the combined width of the rack channels; they are designed for multiple rack installations
- Slotted mounting holes for easy installation; able to mount beneath pre-installed equipment
- Includes 12-24 mounting hardware
- Constructed of 12-gauge steel
- Sold individually

PART NO.	INSIDE RING DIMENSIONS	RACK SPACE	CABLE CAPACITY	SHIP WEIGHT
<b>CR-93S-1B</b>	0.91"W x 2.50"D	2	35	1 lb
<b>CR-93S-2B</b>	2.19"W x 2.50"D	2	85	1 lb
<b>CR-93S-3B</b>	0.91"W x 4.75"D	2	70	1 lb
<b>CR-93S-4B</b>	2.19"W x 4.75"D	2	165	1 lb

Black finish.

### Cable Brackets



Cable Bracket mounted.

- Attach to any equipment rack to secure cable
- Used for routing vertically
- Includes 12-24 mounting hardware
- Constructed of steel

PART NO.	DIMENSIONS	SHIP WEIGHT
<b>CB-93-6</b>	0.75"H x 0.71"W x 6.00"D	1 lb
<b>CB-93-7</b>	0.75"H x 0.71"W x 7.00"D	1 lb
<b>CB-93-8</b>	0.75"H x 0.71"W x 8.00"D	1 lb

Gray finish. Add "B" to part number for black finish.

### Combination Organizers - Front/Rear

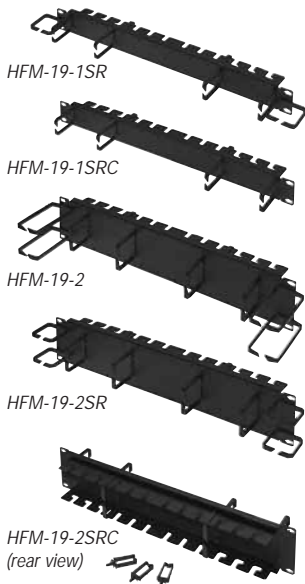

Assure systematic cable delivery with Combination Organizers. Mounted between patch panels, they route patch cords to jacks in front, and horizontal cables to 110 clips in back. There is no need for cable ties, which can be cinched too tightly and hinder performance. The organizers allow plenty of room for horizontal cable and minimize cable strip back, which can have a measurable effect on return loss.

HFM-19-1 series recommended for use with 24-port panels or at the top or bottom of a rack; HFM-19-2 series recommended for use with 48-port panels. HFMs with side rings help manage Swing-EZ Wall Rack installations.

**Features:**

- One device for both patch cord and horizontal cable management
- Maintains pair twists and allows the horizontal cable jacket to remain intact up to the termination
- Eliminates cable stress
- Assures compliance with patch cord minimum bend radius requirements
- Made of 16-gauge steel



Combination Organizers systematically deliver cables horizontally to 110 clips for termination. Vertical Organizers form a rear channel for cables while Vertical Control Brackets help contain them.

PART NO.	FRONT RINGS		BACK RINGS	RACK SPACES (1.75")	SHIP WEIGHT
	VERTICAL	HORIZONTAL	HORIZONTAL		
<b>HFM-19-1SR</b>	1.75"W x 1.75"D	1.00"H x 1.75"D	1.00"H x 1.75"D	1	3 lbs
<b>HFM-19-1SRC*</b>	—	1.00"H x 1.75"D	1.00"H x 1.75"D	1	3 lbs
<b>HFM-19-2</b>	1.75"W x 3.75"D	1.75"H x 1.75"D	2.50"H x 1.62"D	2	5 lbs
<b>HFM-19-2SR</b>	1.75"W x 1.75"D	1.75"H x 1.75"D	2.50"H x 1.62"D	2	5 lbs
<b>HFM-19-2SRC*</b>	—	1.75"H x 1.75"D	2.50"H x 1.62"D	2	4 lbs

Black finish. Plastic clips are shipped loose. User can add to HFM if desired. Homaco does not recommend installing the clips when patch cords with strain relief boots are used. \* For in-cabinet installations.

### Organizer Covers



Organizer Cover (HFM-19-2CV)

Organizer Covers attach to the horizontal rings of Homaco HFM-SRC and FCM-SRC series of organizers. They add a finished look while concealing and protecting patch cords and jacks between moves, adds and changes.

**Features:**

- No tools required for installation
- Steel construction
- HFM-19-1CV mounts on: FCM-19-1SRC, HFM-19-1SRC
- HFM-19-2CV mounts on: FCM-19-2SRC, HFM-19-2SRC

PART NO.	DIMENSIONS	RACK SPACES (1.75")	SHIP WEIGHT
<b>HFM-19-1CV</b>	1.75"H x 19.25"W x 0.31"D	1	2 lbs
<b>HFM-19-2CV</b>	3.50"H x 19.25"W x 0.31"D	2	3 lbs

Black finish.

# Cable Management Products

## Proper Use of Combination Organizers

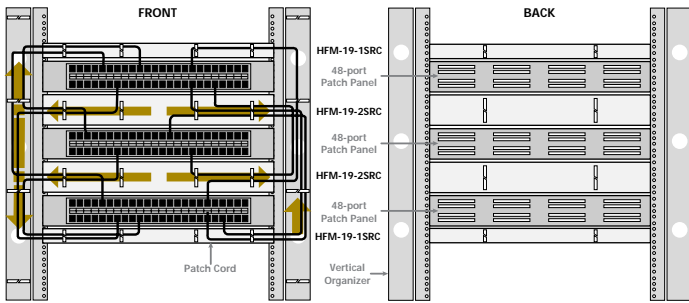

HFM's help create a clean, standard-compliant installation that is easy to access for moves, adds and changes.

## Interbay Organizers



Interbay Organizers (FCM-19-4XL, FCM-19-2XL and FCM-19-1XL) TOP and (FCM-19-2XLH) ABOVE.

Ideal for bulk routing patch cords between bays and within bays to eliminate congestion, Interbay Organizers are larger in capacity than patch cord organizers. Express routes make it easy to trace and maintain circuits.

### Features:

- FCM-19-1XL, FCM-19-2XL and FCM-19-2XLH should be mounted at the top, center or bottom of equipment racks;

FCM-19-2XLH features feed-through holes to accommodate front-to-back jumpering

- The larger-capacity FCM-19-4XL is mounted at the top or bottom of a rack
- Rounded ring edges protect cables
- Constructed of 16-gauge steel
- Welded cable rings also constructed of steel for maximum support

PART NO.	INSIDE DIMENSIONS	DIMENSIONS	CABLE CAPACITY**	SHIP WEIGHT
FCM-19-1XL	1.50"H x 3.50"D	1.75"H x 20.19"W x 4.75"D	84	3 lbs
FCM-19-2XL	3.00"H x 3.50"D	3.50"H x 20.19"W x 4.94"D	200	4 lbs
FCM-19-2XLH*	3.00"H x 3.50"D	3.50"H x 20.19"W x 4.94"D	200	4 lbs
FCM-19-4XL	6.50"H x 3.50"D	7.00"H x 20.19"W x 7.00"D	364	7 lbs

Black finish. \*H = feed-through holes. \*\* Based on .25 cable diameter.

## Interbay Organizer Covers

Interbay Organizer Covers conceal cables while providing a clean appearance.

### Features:

- Hides cables from environmental elements
- Hooks to organizer rings without the use of tools
- Constructed of 18-gauge steel

PART NO.	DIMENSIONS	MOUNTS ON	SHIP WEIGHT
FCM-19-1XLCV	1.81"H x 19.25"W x 1.50"D	FCM-19-1XL	2 lbs
FCM-19-2XLCV	3.50"H x 19.25"W x 1.88"D	FCM-19-2XL(H)	3 lbs
FCM-19-4XLCV	7.00"H x 19.25"W x 2.25"D	FCM-19-4XL	4 lbs

Black finish.

## Jumper Transition Express Trough



Jumper Transition Express Trough (JTR-19-XL shown with FCM-19-2XLH.)

### Features:

- Provides smooth horizontal-to-vertical cable delivery for 19" and 23" racks
- Unit sits within the rings of Homaco Interbay Organizers without the use of tools
- Permits cables to transition vertically without sharp bends; 1" radius complies with cable installation needs
- Two-piece construction is made of 16-gauge steel
- Use with any Homaco Interbay Organizer (purchased separately)

PART NO.	DIMENSIONS	SHIP WEIGHT
JTR-19-XL	1.69"H x 9.94"W x 4.00"D	5 lbs

Black finish.

## Express Cord Routing

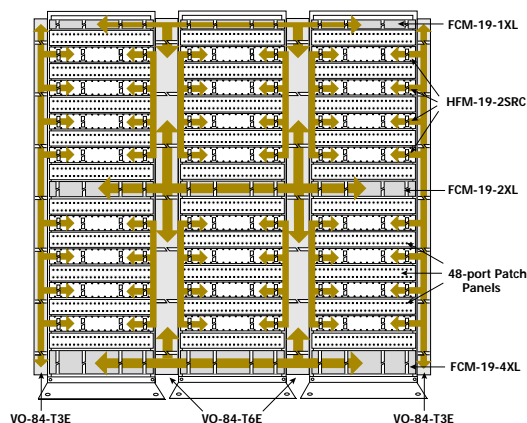

Interbay Organizers provide a convenient path for bulk routing patch cords between equipment racks. Combination Organizers, Patch Cord Organizers and Vertical Organizers are used to route patch cords within equipment racks.

## Cable Management Products

### Patch Cord Organizers

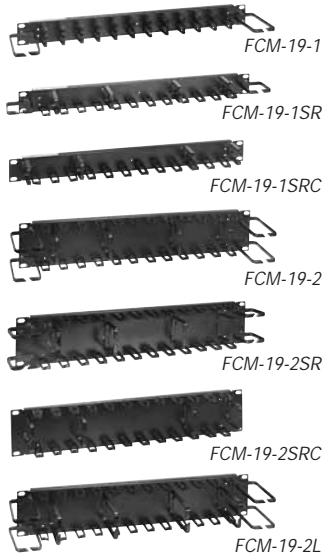

Patch Cord Organizers create horizontal and vertical pathways for frontside cable management. Designed for use with patch panels, the organizers simplify the tracing, identifying and rerouting of patch cords. To handle both patch cord and backside cable management in the same rack space, use Homaco Combination Organizers.

**Features:**

- FCMs with side rings help manage Swing-EZ Wall Rack installations
- Use Panel Adapters when mounting organizers to 23" racks (page 151)
- Made of 16-gauge steel
- 1SR and 1SRC made of 18-gauge steel

PART NO.	INSIDE RING DIMENSIONS		RACK SPACES (1.75")	SHIP WEIGHT
	VERTICAL	HORIZONTAL		
<b>FCM-19-1</b>	1.75"W x 3.75"D	—	1	3 lbs
<b>FCM-19-1SR</b>	1.75"W x 1.75"D	1.00"H x 1.75"D	1	3 lbs
<b>FCM-19-1SRC*</b>	—	1.00"H x 1.75"D	1	3 lbs
<b>FCM-19-2</b>	1.75"W x 3.75"D	1.75"H x 1.75"D	2	4 lbs
<b>FCM-19-2SR</b>	1.75"W x 1.75"D	1.75"H x 1.75"D	2	4 lbs
<b>FCM-19-2SRC*</b>	—	1.75"H x 1.75"D	2	4 lbs
<b>FCM-19-2L</b>	1.75"W x 3.75"D	1.75"H x 3.75"D	2	4 lbs

Black finish. \* Recommended for use with Vertical Organizers (page 155). Can also be used in cabinet installations.

### Half Space Cable Organizer



The half-space cable organizer provides management for the routers, switches, media converters, transceivers, hubs and repeaters that do not take up a full rack space. The front-side cable manager will accommodate the smallest possible rack space, while providing the management needed to simplify the tracing, identifying and rerouting of cables.

**Features:**

- Clips can be mounted horizontal or vertical
- Mounts above or below the rack equipment
- Made of 16-gauge steel
- 12-24 mounting hardware included
- Mounts on 19" Equipment Rack, Swing-EZ Wall Rack, or Hinged Wall Adapters, or cabinet
- Plastic clips shipped loose

PART NO.	DIMENSIONS*	RACK SPACES	SHIP WEIGHT
<b>FCM-19-HS</b>	0.84"H x 19.00"W x 1.88" D	.5	1 lb

Black finish. \*Dimension includes clips installed.

### Fanning Strips



Fanning Strip (310-19E)

- Attach to 19" or 23" equipment racks
- Plastic clips manage horizontal cable runs
- Three adjustable depths from 1" to 4"

- Constructed of 16-gauge steel
- Mounting hardware included

PART NO.	NO. OF CLIPS	DIMENSIONS	SHIP WEIGHT
<b>310-19E</b>	16	1.00"H x 19.25"W x 4.88"D	1 lb
<b>310-23E</b>	20	1.00"H x 23.25"W x 4.88"D	1 lb

Smoke gray finish with black clips. Add "B" to part number for black finish.

### Touch-Up Paint

Homaco Touch-Up paint is available to repair minor scratches to the finish of painted Homaco products. The aerosol can easily sprays paint to product surface and dries within minutes.

**Note:** Can of paint ships as a separate, single unit; UPS ground shipments only.

**Features:**

- Available in colors to repair scratches of Homaco painted products
- Can provides 12 ounces of dry enamel spray
- Paint dries quickly

PART NO.	DESCRIPTION	COLOR MATCHES	SHIP WEIGHT
<b>TUP-BLK</b>	Black	ALL black products	1 lb
<b>TUP-DGRY</b>	Dove Gray	Unequal Flange Racks, Solid Runway, Central Office Kits, TRC Channel Runway & finished accessories (part no. ending in "D")	1 lb
<b>TUP-GRYSTN</b>	Greystone	110D Modules & Frames	1 lb
<b>TUP-HGRY</b>	Homaco Gray	50LS Runway Supports, TR Runway & finished accessories (standard/default color)*	1 lb
<b>TUP-SMKGRY</b>	Smoke Gray	Swing-EZs, Equipment Racks & finished accessories (standard/default color for Swing-EZs, Equipment Racks, Equipment Shelves, Panel Adapters, Blank Fillers, Guard Rails, Dust Covers)	1 lb

\*Call Inside Sales for correct color match.